

PRODUCT TECHNICAL SPECIFICATION

Lithium Thionyl Chloride Battery

Model: ER14250MR-150

Issue Date: March 12, 2013

Task Authorization	Name	Position	Signature	Date
Prepared	曹浪	Lithium Battery R&D Engineer		
Checked	徐瑛	Lithium Battery Technology Department Manager		
Approved	袁中直	Research & Development Center General Manager		

EVE ENERGY CO., LTD.

EVE Industrial Park, Xikeng Industrial Zone, Huihuan
Town, Huizhou, Guangdong, China

TEL: +86-752-2606966 FAX: +86-752-2606033

1 Scope

The document applies to ER14250MR-150 (Li/SOCl₂) battery supplied by EVE Energy Co., Ltd.
Specify quality, test method, performance, quality assurance and others.

2 Battery type

Lithium Thionyl Chloride Battery.

3 General electrical characteristics

No.	Item	Characteristic	Remarks
1	Type	ER14250MR-150	Half-Spiral type battery
2	Nominal voltage	3.6V	Tested with 36KΩ(0.1mA) load at +20°C
3	Nominal capacity	0.80Ah	At 3.6KΩ(1.0mA) load, 2.0V cut off,+20°C
4	Maximum recommended continuous current	20mA	To get 50% of the nominal capacity at +20°C with 2.0V cut off(Higher currents possible,consult EVE).
5	Operating temperature	-40°C~+150°C	Operation at temperature different from ambient may lead to reduced capacity and lower voltage plateau reading, Consult EVE.
6	Self-discharge rate	≤1%	Less than 1% per year of storage at +20°C.
7	Outside dimensions	Diameter:14.5mm Max Height:25.4mm Max.	See the Figure 4
8	Nominal weight	9g	
9	Volume of battery	4.2cm ³	

4 Appearance and structure

4.1 Appearance

Appearance will be free from flaw, stain, deformation, electrolyte leakage and other defects.

4.2 Structure

ER14250MR-150 are "Half-Spiral design" batteries.

Hermeticity is ensured by a glass-to-metal seal using the compression seal technology. (In a standard helium pressure, leakage rate ≤10⁻⁷atm.cc/sec).

5 Performance

Item	Test condition	Typical values
1) Open circuit voltage		
Room temperature	20°C±2°C	3.63V~3.73V
High temperature	100°C±2°C	3.62V~3.72V
High temperature	150°C±2°C	3.64V~3.74V
2) load voltage		
Room temperature	660Ω(5.0mA) load 10min	≥3.15V
3) Operation voltage:discharge with 660Ω(5.0mA) load.Orientation: upside		
Room temperature	20°C±2°C	≥3.30V
High temperature	100°C±2°C	≥3.30V
High temperature	150°C±2°C	≥3.30V
4) Service life:at 660Ω(5.0mA) load, 2.0V cut off.Orientation: upside		
Room temperature	20°C±2°C	≥120h(0.60Ah)
High temperature	100°C±2°C	≥120h(0.60Ah)
High temperature	150°C±2°C	≥100h(0.50Ah)
5) Electrolyte leakage test		
In testing 1-4	No leakage	
6) Deformation		
In testing 1-4	The cell size don't overstep standard.	

6 Safety and environmental performance

6.1 Environmental test

6.1.1 Temperature cycling test

The batteries are to be placed in a test chamber and subjected to the following cycles: raising the chamber temperature to 70±3°C within 30min and maintaining for 4h, then reducing the chamber temperature to 20±3°C and maintaining for 2h, then reducing to -40±3°C and keep it for 4h, at last, raising to 20±3°C with 30min. Repeating the sequence for a further 10 cycles. Pass/Fail criteria: the samples shall not explode or catch fire. In addition, the samples shall not leak.

6.1.2 Low pressure (Altitude Simulation) test

Sample batteries are to be stored for 6h at an absolute pressure of 11.6KPa(1.68psi) and a temperature of $20\pm 3^{\circ}\text{C}$ ($68\pm 5^{\circ}\text{F}$) .

Pass/Fail criteria: The samples shall not explode or catch fire as a result of the Altitude Simulation Test. In addition the samples shall not vent or leak.

6.1.3 Heating test

A battery is to be heated in a gravity convection or circulating air oven. The temperature of the oven is to be raised at a rate of $5\pm 2^{\circ}\text{C}$ per minute to a temperature of $130\pm 2^{\circ}\text{C}$ and remain for 10 minutes at that temperature before the test is discontinued.

Pass/Fail criteria: The samples shall not explode or catch fire.

6.2 Mechanical test

6.2.1 Free fall test

According to the IEC, each cell should be dropped 2 times from 1m height onto cement ground (total 6 times).

Pass/Fail criteria: The samples shall not explode or catch fire. In addition, the samples shall not vent or leak.

6.2.2 Vibration test

A battery vibration frequency is to be varied at the rate of 1 hertz per minute between 10 and 55 hertz, and return in not less than 90 or more than 100 minutes. The battery is to be tested in three mutually perpendicular directions

Pass/Fail criteria: The samples shall not explode or catch fire. In addition, the samples shall not vent or leak.

6.2.3 Impact test

A test sample battery is to be placed on a flat surface. A 5/8inch(15.8mm) diameter bar is to be placed across the center of the sample. A 20pound(9.1kg)weight is to be dropped from a height of $24\pm 1\text{inch}$ ($610\pm 25\text{mm}$)onto the sample. (See Figure 1).

Pass/Fail criteria: The samples shall not explode or catch fire.

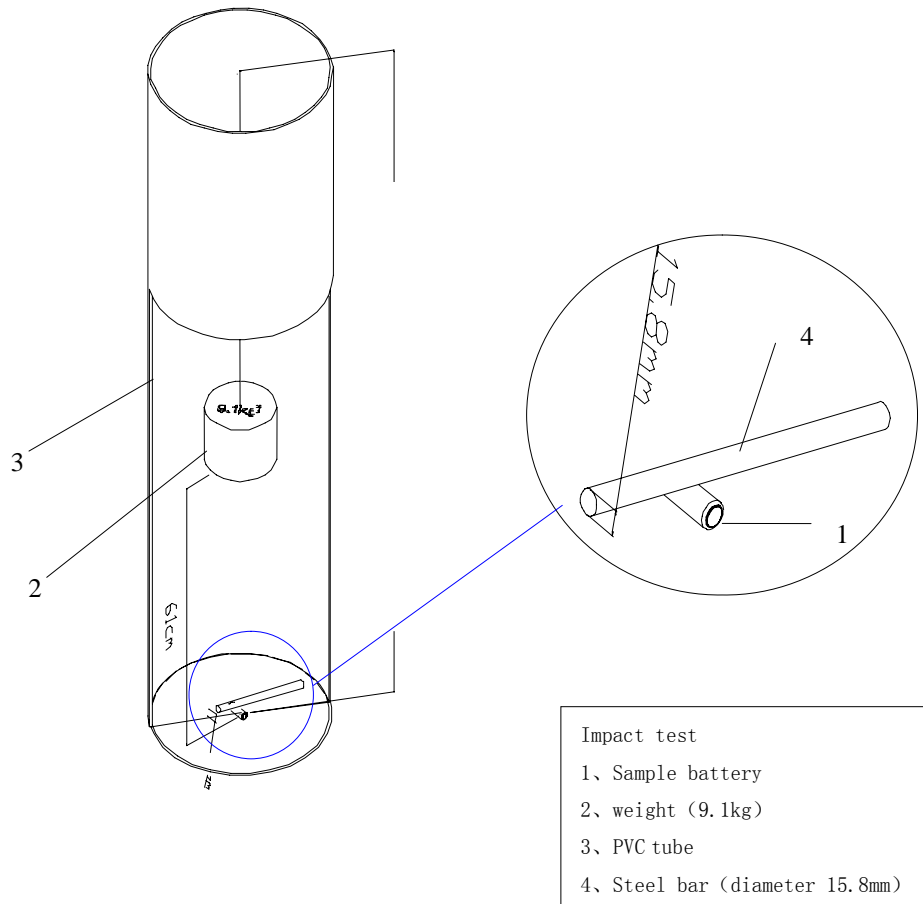

Figure 1 Impact test

6.2.4 Shock test

The cell is to be secured to the testing machine by means of a rigid mount which supports all mounting surfaces of the cell. Each cell shall be subjected to a total of three shocks of equal magnitude. The shocks are to be applied in each of three mutually perpendicular directions unless it has only two axes of symmetry in which case only two directions shall be tested. Each shock is to be applied in a direction normal to the face of the cell. For each shock the cell is to be accelerated in such a manner that during the initial 3 milliseconds the minimum average acceleration is 75g (where g is the local acceleration due to gravity). The peak acceleration shall be between 125 and 175g. Cells shall be tested at a temperature of $20 \pm 5^\circ\text{C}$ ($68 \pm 9^\circ\text{F}$).

Pass/Fail criteria: The samples shall not explode or catch fire. In addition, the sample shall not vent or leak.

6.2.5 Crush Test

A battery is to be crushed between two flat surfaces. The force for the crushing is to be applied by a hydraulic ram with a 1.25 inch (32mm) diameter piston. The crushing is to be continued until a pressure reading of 2500psig (17.2MPa) is reached on the hydraulic ram, applied force of 3000pounds (13kN). Once the maximum pressure has been obtained it is to be released.

Pass/Fail criteria: The samples shall not explode or catch fire.

6.3 Abuse test

The description of abuse tests is for demonstration purposes only. During handling and application of lithium batteries, abusive conditions must be avoided. Any application or test requiring performance beyond the limits given here must be approved by EVE.

6.3.1 Short-circuit test

Each test sample, in turn, was short-circuited by connecting the positive and negative terminals of the sample with a circuit load having a maximum resistance of 0.1 ohm. The sample was discharged until a fire or explosion was obtained, or until it had reached a completely discharged state of less than 0.1 volts and the cell case temperature had returned to +10°C (+18°F) of ambient temperature.

Pass/Fail criteria: The samples shall not explode or catch fire.

6.3.2 Abnormal charging test

Each test sample battery is to be subjected to a charging current of three times the current I_c , specified by the manufacturer by connecting it in opposition to a dc-power supply. The specified charging current is to be obtained by connecting a resistor of the specified size and rating in series with the battery.

The test charging time is to be calculated using the formula:

$$T_c = 2.5 * C / (3 * I_c)$$

In which

T_c —charge time, hour, $T_c \geq 7$ Hour;

C —Nominal capacity, Ah;

I_c —Max. charging current, mA. Max. charging current of ER14250MR-150 is 0.005A

Pass/Fail criteria: The samples shall not explode or catch fire.

6.3.3 Forced-discharge test

For single cells in series, a completely discharged cell was force-discharged by connecting it in series with fully charged cells of the same kind. The number of fully charged cells connected in series with the discharged cell equaled the maximum number less one of the cells covered for series use.

Pass/Fail criteria: The samples shall not explode or catch fire.

References to safety standards

*UL Underwriters Laboratories "Standard Lithium Battery"—UL 1642—Fourth Edition—2009.

***IEC International Electro technical Commission International safety standards for lithium batteries "IEC 60086-4"—Third Edition – 2007

7 Product mark

7.1 battery's label specification

- ① type ② nominal voltage
③ positive and negative electrode mark ④ data code ⑤ safety warning

7.2 date coding

Date code will be marked on the sleeve of battery.

Method: MM YY XXX

“MM” mean: month “YY” mean: year “XXX” mean: Order serial number

8. Incoming inspection

Before shipping, EVE will 100% check open circuit voltage of the battery (OCV) and the load voltage. Also EVE will sampling tests the battery capacity, visual appearance and size. As for the customer's incoming inspection, EVE recommended sampling according to GB2828.1-2003, GB2829-2002 standard. Specific sampling plans, test items, Pass/Fail criteria should be consultation.

9 Storage

EVE lithium batteries should be stored in a cool, clean, dry environment, the recommended temperature is $\leq +30^{\circ}\text{C}$, relative humidity $\leq 60\%$, should avoid contact with corrosive materials, away from fire and heat.

At higher temperatures storage battery is possible, but it may affect the following battery capacity and Initial Values.

10 Safety

10.1 We propose to use EVE cell process, need to comply with the following provisions

- Before use, do not remove the battery from the original packaging.
- The battery scattered placed together in order to avoid accidental short circuit.
- Do not heated above 165°C or incinerated.
- Do not recharge the battery. The battery can withstand instantaneous charging current of less than 5mA, instant charging voltage is less than 4.0V.
- Do not weld or solder directly to battery.
- Do not mix the new and used batteries or different brand battery.
- Do not open or deform battery
- Do not fix the positive and cathode reversely

EVE Battery verified by Underwriters Laboratory as "engineers replace batteries."

10.2 Design aids and instructions for use

The following diagram shows by the Underwriters Laboratory recommended the protection of memory backup circuit reverse charging circuit, shown in Figure 3. If the resistance R is diode replaced by Figure 2 is also available. Set such a safety device in the circuit board is absolutely necessary, which includes a backup battery and power supply in parallel. Safety devices should be as close as possible the battery. Otherwise, do not intend to short circuit in the adjacent PCB or bad solder joints, may bypass the safety device, so that the power supply through the reverse (charging) current through the battery.

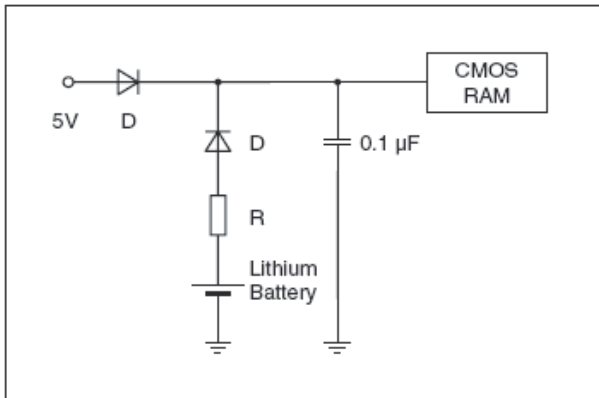

Figure 2

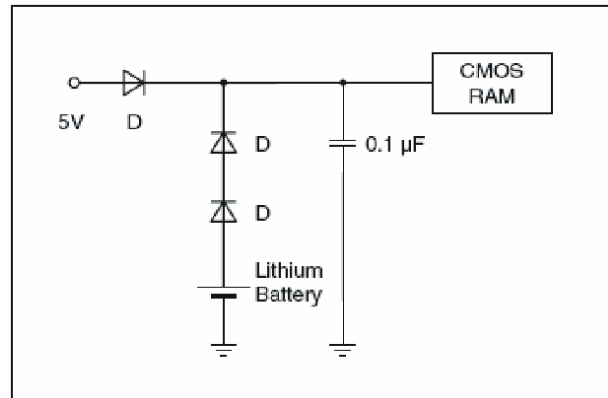

Figure 3

11 Transport

ER14250MR-150 battery has been proven to meet the requirements of each test in the UN Manual of Tests and Criteria, Part III, subsection 38.3 (Document No.: ST/SG/AC.10.11/Rev 4th). According to the United Nations "Recommendations on the Transport of Dangerous Goods Model Regulations" (Document No.: ST/SG/AC.10/1- Rev16th), The ER14250MR-150 battery's lithium content is less than 1g, So ER14250MR-150 battery should transport as class 9 dangerous goods.

12 Remark of production duty

You must strictly operate according to specification and remark of EVE ENERGY CO., LTD. Reason of error use rise fire, explosion, and so hurt body and lose wealth. We don't burden any duty on any contretemps raised from error use..

13 Cell drawing(Unit: mm)

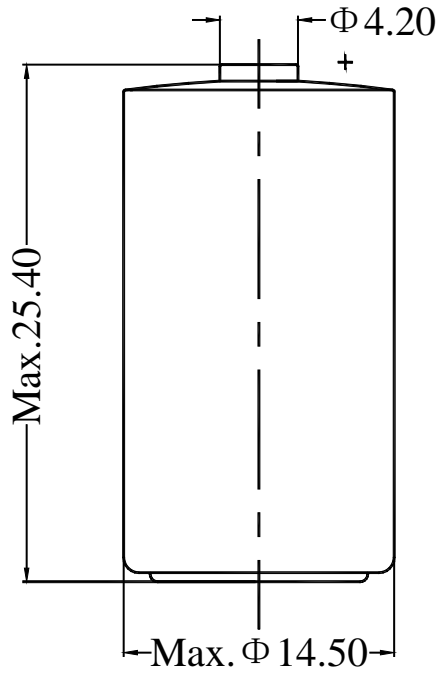

Figure 4 Cell drawing